

LIMITED WARRANTY

Aroma Housewares Company warrants this product free from defects in material and workmanship for one year from provable date of purchase in continental United States.

Within this warranty period, Aroma Housewares Company will repair or replace, at its option, defective parts at no charge, provided the product is returned, freight prepaid with proof of purchase and U.S. \$8.00 for shipping and handling charges payable to Aroma Housewares Company. Before returning an item, please call the toll free number below for return authorization number. Allow 2-4 weeks for return shipping.

This warranty does not cover improper installation, misuse, abuse or neglect on the part of the owner. Warranty is also invalid in any case that the product is taken apart or serviced by an unauthorized service station.

This warranty gives you specific legal rights and which may vary from state to state and does not cover areas outside the United States.

AROMA HOUSEWARES COMPANY
6469 Flanders Drive
San Diego, California 92121
1-800-276-6286
M-F, 8:30 AM - 5:00 PM, Pacific Time
Website: www.aromaco.com

Command Performance™ 3.5 Liter Stainless Steel Deep Fryer



Instruction Manual & Recipe Guide

Model: ADF-192SSCP

RECIPES

Preheat oil to 375 °F. Heat 2 teaspoons of corn oil in a fry pan over medium heat. Add garlic, ginger and green onions. Cook for 2 minutes. Add button mushrooms and black mushrooms. Cook for 3 minutes. Add salt to taste. Stir in peanuts, carrots, bean sprouts and sesame oil, turn off heat.

To prepare egg roll wrappers put 2 ½ teaspoons filling in each one. Roll up, tucking in edges over filling. Seal the edge with a drop of thick flour paste.

Deep fry 3 rolls at a time for approximately 4-6 minutes or until the egg rolls are golden brown all sides. Carefully lift the cooked egg rolls from the fryer. Let drain in the basket then pat dry with paper towels.

Fried Chicken Tenders

Vegetable oil for frying

4 boneless, skinless chicken breasts

1 cup bread crumbs

1 teaspoon lemon juice

1 tablespoon dried basil leaves

1 cup flour

½ teaspoon of salt and pepper

Preheat oil to 350°F. Cut the chicken in even strips, about 1 inch wide and 1 inch thick. Marinate chicken with salt, pepper, basil leaves and lemon juice for about 30 minutes. Coat chicken breasts evenly with flour and bread crumbs.

Deep fry chicken strips at 350°F for 8-10 minutes. Let drain in the basket and serve with honey mustard or sweet and sour sauce

RECIPES

Deep Fried Onion Blossom

Canola oil or blended vegetable oil for frying

1 large onion

2 eggs

½ cup beer

½ cup milk

2 cups all-purpose flour

½ teaspoon baking soda

½ teaspoon black pepper

Preheat oil to 375° F. Peel onion and cut the bottom off. Cut the onion into ¾-inch wedges without cutting all the way through the base.

Soak onion in ice cold water until wedges open (approximately 7-12 minutes). Drain onion and pat dry. Mix together eggs, beer and milk. In a separate bowl mix flour, baking soda and black pepper.

Dust the onion with the flour mixture. Dip the onion in the batter. Re-dust with the flour mixture. Shake off the excess. Make sure that the onion is completely coated.

Carefully lower the blossom into hot oil being very careful to avoid splattering.

Cook for 2 minutes. Turn onion and cook for an additional 2 minutes or until golden brown. Lift the cooked blossom from the oil. Sprinkle with salt and pepper to taste.

Vegetarian Egg Rolls

Corn oil for frying

6 egg roll wrappers

2 green onions, minced

¼ lb. minced white button mushrooms

2 oz. grated carrot

1 teaspoon minced ginger and garlic

2 soaked and minced dried shitake mushrooms

1 teaspoon sesame oil

1 teaspoon salt

¼ cup bean sprouts

1 teaspoon chopped roasted peanuts

Congratulations!

You will find the Command Performance™ Stainless Steel Deep Fryer to be one of the most useful and versatile appliances in your home. Have fun and enjoy it!

Please read all instructions carefully before first use.



Published By:

Aroma Housewares Co.
6469 Flanders Drive
San Diego, CA 92121
U.S.A.
1-800-276-6286
www.aromaco.com

IMPORTANT SAFEGUARDS

Basic safety precautions should always be followed when using electrical appliances, including the following:

1. Read all instructions before first use.
2. Do not touch hot surfaces. Use handles or knobs.
3. To protect against electrical shock, do not immerse the appliance or electrical cord in water or other liquid.
4. Close supervision is necessary when any appliance is in use near children. This appliance is not intended to be used by children.
5. Do not leave appliance unattended while in use.
6. Unplug from outlet when not in use and before cleaning. Allow deep fryer to cool completely before putting on or taking off parts, and before cleaning.
7. Do not operate any appliance with a damaged cord or plug or after the appliance malfunctions or has been damaged in any manner. Return appliance to the nearest authorized service facility for examination, repair or adjustment.
8. The use of accessory attachments not recommended by the appliance manufacturer may result in fire, electric shock or injury.
9. Do not use outdoors.
10. Do not let cord touch hot surfaces or hang over the edge of a counter or table.
11. Do not place on or near a hot burner or in a heated oven.
12. Extreme caution must be used when using or moving an appliance containing hot oil or other hot liquids.
13. Do not use the appliance for other than intended use.
14. To disconnect power cord, flip the "ON/OFF" switch to "OFF" then remove plug from wall outlet.
15. Never overfill the fryer with oil. Use minimum/maximum level indicators located on the inside of the cooking pot.
16. Use only metal cooking utensils in the fryer as rubber or plastic utensils will become damaged from the hot oil. Do not leave metal utensils in the fryer as they will become dangerously hot.
17. Always attach plug to appliance first, then plug cord into the wall outlet. to disconnect, turn any control to "off", then remove plug from wall outlet.
18. Be sure handle is properly attached to basket and locked in place. See page 4 for assembly instructions.

This appliance is intended for household use only.

SAVE THESE INSTRUCTIONS

RECIPES

Fontina Cheese Fritos (Fritters)

Corn oil for frying
1 minced clove of garlic
¾ lb. chilled fontina cheese
2 eggs
½ cup minced fresh basil
1 ½ cup unbleached flour
⅔ cup ice water
1 teaspoon baking powder
3 teaspoon olive oil
salt to taste

Preheat oil to 350°F. Cut cheese into 1-inch cubes. Separate the egg yolks from the whites and set the whites aside. Mix egg yolks and garlic in a bowl. Add baking powder, flour, ½ teaspoon salt, olive oil and water. Mix until smooth. Let rest at room temperature for 2 hours.

Beat egg whites with a pinch of salt until barely stiff. Fold into batter along with minced basil.

Dip cheese chunks into batter. Drip off excess batter. Lower cheese chunks into oil until golden, approximately 1-1 ½ minutes. Remove from basket and serve immediately.

RECIPES

Crumb-Coated Basil Fried Chicken

Canola oil for frying
4 skinless, boneless chicken breasts
1 cup breadcrumbs
½ cup buttermilk
1 teaspoon yellow mustard
½ teaspoon of salt
½ teaspoon of pepper
4 teaspoons dried, chopped basil
2 tablespoons melted butter or margarine

Preheat oil in deep fryer to 350°F. Combine buttermilk, mustard and salt in a large bowl. Coat chicken breasts evenly with the mixture. Combine breadcrumbs, basil and pepper in a medium dish. Add melted butter and mix well.

Move chicken breasts from the buttermilk mixture to the dish with the breadcrumb mixture and coat each chicken breast thickly and evenly. Deep fry one chicken breast at a time for 8-10 minutes, until tender and golden brown.

Fried Jumbo Shrimp

Canola oil for frying
14 large shrimp in the shell
1 teaspoon salt
½ teaspoon white pepper powder
3 teaspoons cornstarch
1 teaspoon Japanese rice wine

Preheat oil in deep fryer to 350°F. Peel and remove the vein of each shrimp by cutting a slit on the shell along the back of each shrimp. Season shrimp with rice wine and salt. Let stand for 20 minutes. Evenly dust each shrimp with cornstarch. Add shrimp to the frying basket and deep fry for 4 to 5 minutes, until all shrimp look crispy, golden and butterflied. Carefully remove the shrimp from frying basket and arrange on a plate. Garnish with lettuce leaves and lemon slices.

SHORT CORD INSTRUCTION

1. A short power-supply cord is provided to reduce risk resulting from becoming entangled in or tripping over a longer cord.

POLARIZED PLUG

This appliance has a **polarized plug** (one blade is wider than the other); follow the instructions below:

To reduce the risk of electric shock, this plug is intended to fit into a polarized outlet only one way. If the plug does not fit fully into the outlet, reverse the plug. If it still does not fit, contact a qualified electrician. Do not attempt to modify the plug in any way.

DO NOT DRAPE CORD !



BREAK-AWAY CORD

This stainless steel deep fryer has been specially designed with a “break-away” cord, making deep frying safer than ever. The magnetic plug will only attach to the appliance in one direction. The plug is clearly marked “This Side Up.” The bottom of the plug also has a notch, which will prevent you from attaching the plug the wrong way. The magnets on the plug and appliance automatically make the connection. Should you accidentally move or tug on the power cord while in use, it will automatically pull away from the appliance, breaking the connection and preventing the hot oil tank from tipping over. **DO NOT** place the appliance on top of the cord or run the cord around the unit. This will prevent the magnetic cord from detaching easily if the cord is accidentally tugged on.

Always attach the magnetic plug to the appliance first and then to the wall outlet. After use, unplug from the wall outlet first, and then remove the magnetic plug from the appliance.

This appliance is for household use only.

PARTS IDENTIFICATION

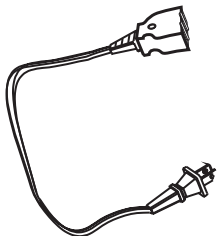
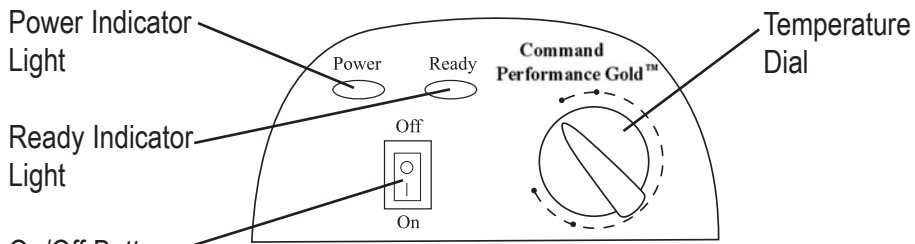
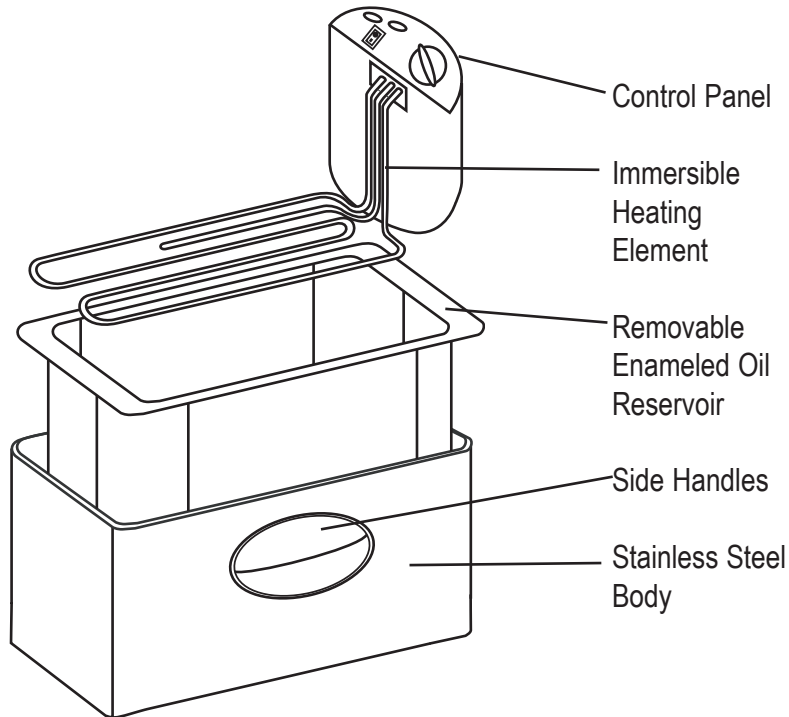

Break-Away Magnetic Plug and Cord

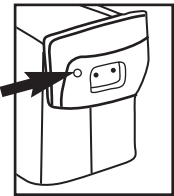

Manual Reset Button

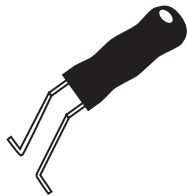

Frying Basket Handle

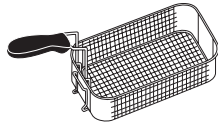

Frying Basket

HOW TO CLEAN AND STORE

Replacing the Filter:

The life of the filter varies according to the type of food fried and the frequency of use. Command Performance Gold recommends the filter be replaced after 30-40 uses.

1. Open detachable filtering vent.
2. Remove the old filter.
3. Place the new filter over the vents, and snap on the detachable filtering vent.

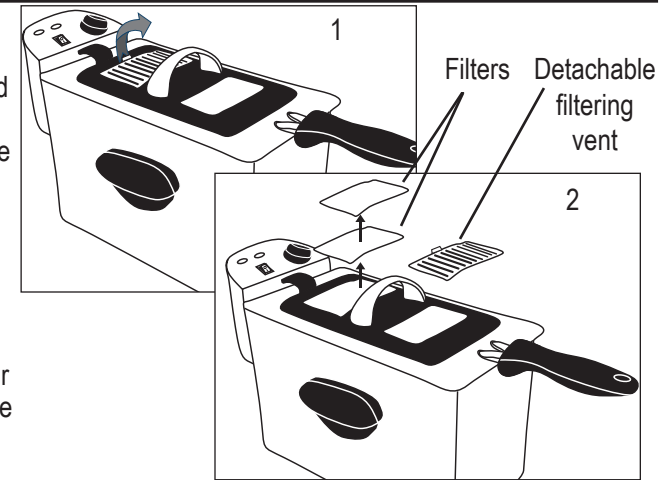

COOKING GUIDES

Batter Suggestions:

Coating the food with batter to fry not only maintains texture and flavor but also preserves the juice and essence of food after deep frying.

Egg Coating

- Mix 2 whole eggs with 1 ½ tsps of vegetable oil, and add a dash of salt and pepper.

Crispy Coating

- Beat ½ cup of milk and one whole egg together. Separately combine ½ cup of flour and your favorite seasonings (salt, pepper, garlic etc.). Dip food into milk and egg mixture then coat in seasoned flour.

Egg Batter

- Mix 2 egg yolks, ¾ cup of flour, 1 ½ tsps of oil, ½ tsp of salt and 1 cup of milk. The amount of milk should be adjusted to create the density of the batter desired. Dip food in batter and fry.

Beer Batter

- Combine 1 ½ cups of flour and 1 ½ cups of beer in a large bowl. Cover and allow the batter to sit at room temperature for 3 hours or so. Dip food in batter and fry.

Helpful Tips for Frying Food Coated with Batter:

- Check that the food is evenly and thinly sliced as it helps to ensure that the food is fried evenly and perfectly.
- Shake off the excess flour or coating such as bread crumbs before frying.

HOW TO CLEAN AND STORE

Changing the Oil:

- The oil may NOT need to be changed every time you use the deep fryer. It may be stored and reused.
- When frying lightly flavored food, we recommend changing the oil after approximately 5 to 8 uses. If you are frying heavier flavored foods, the oil will need to be changed more often.

To Store Oil:

1. Be sure the fryer has completely cooled (approximately 4 hours) and is unplugged prior to storing the oil.
2. Before storing the oil, be sure to filter out any food particles that may be left in the oil.
 - To filter: Use a mesh strainer over a bowl to separate food particles from the oil. For best results, you can line the mesh strainer with two layers of cheesecloth. Once the oil is strained, place in a container that can be sealed tightly and place in the refrigerator.

It is important to replace the oil if you notice any of the following:

- An unpleasant odor to the oil
- Excessive smoking when heating the oil.
- Oil is dark in color.
- Oil has been stored for a long period of time.

To Clean Oil Tank, Fryer Lid and Fry Baskets:

1. Disassemble the unit by reversing the steps of assembly on page 4.
 2. Dispose of the oil in a jar or can. Oil should NOT be poured into the drain of your sink. If you are storing your oil for future use, see Storing Oil above.
 3. To clean the lid and filters, lift the filter lid and remove the two filters. Wash the filters in warm, soapy water and rinse thoroughly. Allow the filters to dry completely.
 4. All parts of your fryer are fully immersible and dishwasher safe EXCEPT FOR THE CONTROL PANEL WITH THE HEATING ELEMENT AND THE MAGNETIC PLUG.
 5. To clean the heating element, rinse with water or immerse in soapy water. Wipe with damp cloth and dry thoroughly before next use.
 6. Dry the oil reservoir completely before next use.
 7. Clean the body of the fryer with a damp cloth and then dry.
 8. Place filters back into the lid for future use.
- **Do not use harsh abrasive cleaners or products that are not considered safe to use on nonstick coatings.**
 - **Do not attempt to cool the unit by pouring cold water into the pot.**
 - **Do not immerse the power cord or control panel in water or any other liquid.**

HOW TO USE

Before First Use:

1. Read all instructions and important safeguards.
2. Remove all packaging materials and make sure items are received in good condition.
3. Tear up and discard all plastic bags as they can pose a risk to children.
4. Wash accessories and enameled oil pan in warm soapy water. Rinse and dry thoroughly. The heating element can be immersed in water, but never immerse the control panel. Dry the heating element thoroughly before use.
5. Wipe the body clean with a damp cloth.
6. Place the deep fryer on a level, stable surface.
 - **Do not use abrasive cleaners or scouring pads.**
 - **Do not immerse the magnetic cord, plug or control panel in water at any time.**

Assembling the Fry Basket Handle: (See Diagram Below)

- Squeeze handle prongs together and insert through wire loop
- While releasing handle prongs, slip the handle prong wings through the prong wing slots

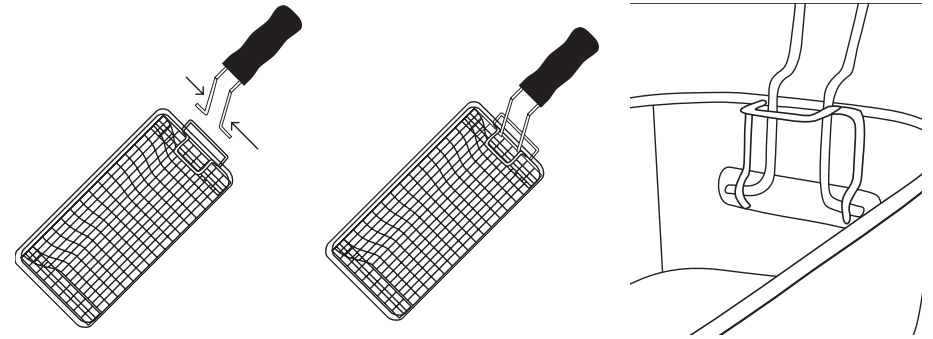

Choosing an Oil:

1. We recommend the following oils for healthier deep-frying: corn, safflower, or blended vegetable oil. These oils are cholesterol-free and low in saturated fats.
2. We do NOT recommend using animal fats or vegetable shortening as they deteriorate quickly when heated. Heavily flavored oils such as extra virgin olive oil should also be avoided.
3. We do not recommend mixing old and new oil together as this spoils new oil faster. The number of times that the frying oil can be used depends on the food that is fried. Oil will generally need to be replaced more often if heavily flavored foods (such as fish) are fried.

HOW TO DEEP FRY

Preheat Oil:

1. Wipe the enameled oil reservoir dry and fill with oil between the maximum and minimum capacity lines only. Put the lid on the deep fryer and make sure the temperature dial is set to "Off".
2. Attach magnetic end of break-away cord to the fryer and then plug the cord into an electric outlet. Flip the "ON/OFF" switch on. The "Power" and "Ready" lights will illuminate.
3. Turn the temperature dial to the desired frying temperature. The "Ready" indicator light will turn off.
4. When the unit has reached the desired temperature, the "Ready" indicator light will re-illuminate.

Note:

- The fryer may give off a slight odor and smoky haze during the first use. This is normal for the first use of the new product, and will not harm it.
- Before plugging the unit into the electric outlet, always make sure that the oil is at least at the minimum marking on the inside of the oil reservoir. If oil is not filled to at least the minimum level, the unit may overheat.

Frying Food:

1. The oil is ready for use when the "Ready" indicator light re-illuminates. Be careful as the oil is now very hot.
2. For foods that are not coated with batter, place directly in the frying basket then lower basket into oil. Be sure not to fill fryer basket more than half full. Overfilling will prevent the food from cooking properly.
3. For food coated with batter, first lower the frying basket into the oil then gently place food directly into the oil. This will prevent food coated with batter from sticking to the bottom of the frying basket.
4. When frying is complete, open lid. Lift basket up out of the oil and place on drain hooks to allow excess oil to drain away.
5. Carefully remove the fried food from the frying basket. Be cautious as the oil is very hot and may splatter from the frying pot.
6. Once frying is finished, turn off deep fryer by unplugging it from the wall outlet.
7. Allow the oil to cool completely before moving or cleaning the appliance.

Note:

- The "Ready" light may turn on and off during operation indicating the temperature is being maintained.
- Always shake frozen foods to remove ice particles prior to frying. Pat dry fresh-cut French fries and other damp foods before frying.
- See the Deep Fry Temperature/Time Chart on page 6 for recommended cooking times.

Caution:

- Do not drop the frying basket or any foods quickly into the hot oil as it could cause injuries by causing the oil to splash or overflow.
- Always allow deep fryer and oil to cool completely before moving or cleaning.

DEEP FRYING REFERENCE CHART

Food Selection	Quantities	Temp. (F°)	Frying Time
French Fries (fresh)	5 oz.	375°	5 min.
French Fries (frozen)	5 oz.	375°	3-5 min.
Chicken Strips (fresh)	6 oz.	350°	3-4 min
Chicken Nuggets (frozen)	5 oz.	370°	3-4 min.
Chicken Drums	Fill basket 1/2 full	370°	7-10 min.
Fish (fresh)	8 oz.	320°	4-6 min.
Fish (frozen)	8 oz.	340°	5-7 min.
Onion Rings (fresh)	6 oz.	350°	2-3 min.
Shrimp	8 oz.	300°	1-2 min.
Fresh Vegetables	10 oz.	370°	2-3 min.
Doughnuts	2-3 pieces	370°	1 min. each side

*Do not fill the frying basket more than half full.

Note: Cooking times and temperatures given here are only a guide. They may vary due to differences in meat and temperature of refrigerated food. Adjust your cooking time and temperature to your preference.

Helpful Hints for Deep Frying

- Prepare food in equal size and thickness for even cooking.
- Do not fill the frying basket more than half full.
- Before deep frying, always remove excess moisture or ice crystals from food by rubbing with paper towel. Moist food may cause hot oil to splatter.

Customer Service

For additional information or questions please contact our Customer Service Department at 1-800-276-6286. Have the product model number ready (Located on the front cover of the manual) to expedite your call.