

AROMA[®]

ICE CREAM MAKER

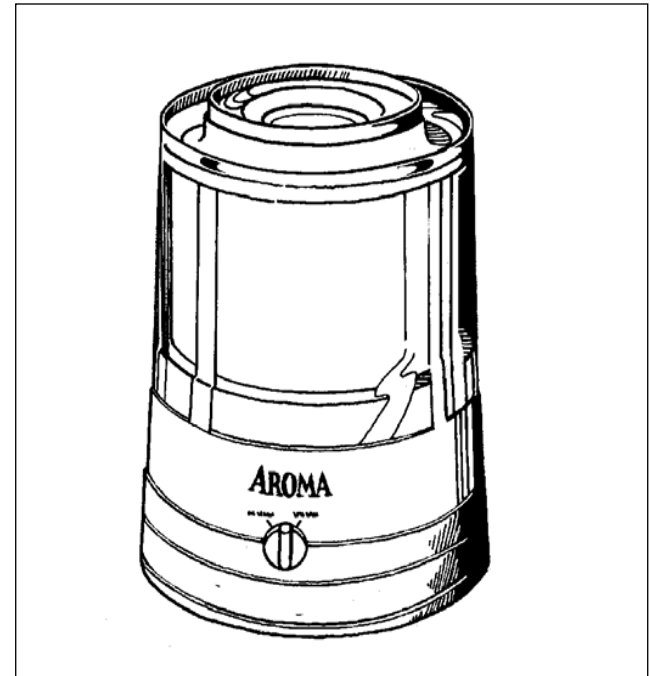

Instruction Manual & Recipes

MODEL: AIC-100
(Capacity: 1 Quart)

Congratulations on your purchase of Aroma's Ice Cream Maker.

*It allows you to make your own rich and creamy **HOMEMADE** ice cream or frozen yogurt with the flip of a switch. You can also make your own favorite, healthy and delicious sherbet, sorbet, ice and frozen drinks fast and easy with Aroma Ice Cream Maker. Enjoy your new Ice Cream Maker, it is fun and easy!*

Please read all instructions carefully before using this product.

Published By:

**Aroma Housewares Company
6469 Flanders Drive
San Diego, CA 92121
U.S.A.**

©2003 Aroma Housewares Company

IMPORTANT SAFEGUARDS

Basic safety precautions should always be followed when using electrical appliances, including the following:

1. Read all **Instructions** before using the appliance.
2. To protect against electrical hazard, do not immerse main body-the motor base or other electrical cord in water or other liquid.
3. Close supervision is necessary when any appliance is used by or near children.
4. Unplug appliance from outlet when not in use, before putting on or taking off parts and before cleaning.
5. Avoid contacting moving parts. Keep fingers, hair, clothing, as well as spatulas and other utensils away during operation.
6. Do not operate any appliance with a damaged cord or plug or after the appliance malfunctions or is dropped or has been damaged in any manner. Return appliance to the nearest authorized service facility for examination, repair or adjustment.
7. The use of accessory attachments not recommended by the appliance manufacturer may cause hazards.
8. Do not use outdoors.
9. Do not let cord hang over edge of table or counter or touch hot surfaces.
10. Keep fingers, utensils, and other foreign objects out of the freezer canister while in use to reduce the risk of injury to persons or to the appliance itself. **DO NOT USE SHARP OBJECTS OR UTENSILS INSIDE THE FREEZER CANISTER.** Sharp objects will scratch and damage the inside of the freezer canister. A rubber spatula or wooden spoon may be used when the appliance is turned off.
11. Use only on appropriate voltage AC outlets. (See rating plate on bottom of appliance.)
12. Do not use the appliance for other than intended use.

This appliance is for household use only.

SAVE THESE INSTRUCTIONS

SHORT CORD INSTRUCTIONS

1. A short power-supply cord is provided to reduce risks resulting from becoming entangled in or tripping over a longer cord.
2. Longer extension cords are available and may be used if care is exercised in their use.
3. If a longer extension cord is used:
 - a. The marked electrical rating of the extension cord should be at least as great as the electrical rating of the appliance.
 - b. The longer cord should be arranged so that it will not drape over the counter top or tabletop where it can be pulled on by children or tripped over unintentionally.

POLARIZED PLUG

If this appliance has a **polarized plug** (one blade is wider than the other) follow the instructions below:

To reduce the risk of electric shock, this plug is intended to fit into a polarized outlet only one way. If the plug does not fit fully into the outlet, reverse the plug. If it still does not fit, contact a qualified electrician. Do not attempt to modify the plug in any way.

PARTS IDENTIFICATION

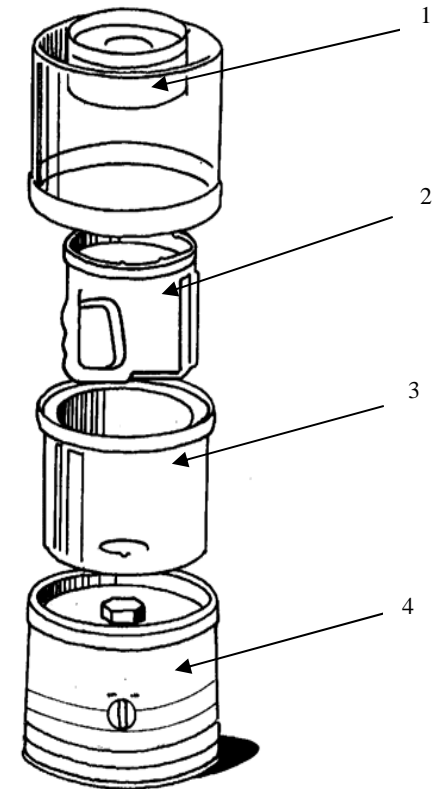

1--Cover with Filling Opening The filling opening in the middle of the cover allows you to add ingredients without stopping the machine.

2--Mixing Paddle The paddle is used to churn the frozen desert and keep the mixture frozen evenly. It remains stationary as freezer canister rotates around it.

3--Freezer Canister The double insulated canister body provides frozen temperature throughout the entire mixing process and it freezes quickly in your freezer.

4--Motor Base The motor base has two- speed switch control for hard and soft consistency.

BEFORE USING

- ◆ Remove all packaging materials from the box, check all the items carefully, and make sure they are all received in good condition.
- ◆ Wash the cover, mixing paddle, and freezer canister in warm soapy water.
- ◆ Rinse and dry all parts thoroughly.
- ◆ Wipe motor base with a damp cloth.

REMEMBER:

- **Do not use abrasive cleaners or hard implements to clean.**
- **Do not immerse motor base in any liquid.**

HOW TO USE

1. **Freeze the Freezer Canister first--** Wash and dry the freezer canister. To protect against freezer burn, wrap the canister in plastic bag first, and then place upright in the back of your freezer where the compartment is coldest. (Usually it is on the top shelf of the refrigerator.) It approximately takes 48 hours to freeze your freezer canister before it is ready for you to make ice cream. It is suggested that you keep the freezer canister in your freezer **48 HOURS** before you make the ice cream.
2. Follow recipes to prepare and process ingredients.
3. Take out the freezer canister from the freezer, remove the plastic bag, and place on the motor base. The freezer canister should be used immediately after removing from the freezer because it begins to thaw once it is taken out.
4. Place the mixing paddle inside the freezer canister with ringside on the top.
5. Pour ingredients into the freezer canister. Keep the mixture below 1/2" of the canister, as the mixture will expand during the freezing process.
6. Place the cover over and lock properly onto the motor base.
7. Plug the power cord into the proper wall outlet. Turn the switch to the left for a HARD consistency (**ICE CREAM**), and to the right for a SOFT consistency (**YOGURT, SHERBET ETC.**)
8. Add extra ingredients as specified in the recipe. Pour through the filling opening in the top of the cover minute before the mixture becomes frozen. It usually takes 40 minute for ice cream and 25 to 30 minutes to make sorbet.
9. Turn the unit off. Take out the mixing paddle from the freezer canister.
10. Use plastic or wooden utensils to serve. Cover the plastic lid on canister before putting it back into freezer.

QUICK COOKING GUIDE

- For making **ICE CREAM**:

Turn on ice cream maker. Mix ice cream in the frozen freezer canister by turning switch to “ICE CREAM” consistency for 40 to 45 minutes. Turn it off and put the freezer canister back into freezer for 2 to 4 hours before serving. For even harder ice cream, it is recommended to place the freezer canister with churned ice cream back into your freezer for 24 hours before serving.

- For making **FROZEN YOGURT**:

Turn on ice cream maker. Mix frozen yogurt in the frozen *freezer canister* by turning the switch to “YOGURT” consistency for 30 minutes. Turn off the ice cream maker and put the *freezer canister* back into your freezer for 1 to 2 hours before serving.

- For making **SORBET/ SHERBET**:

Turn on ice cream maker. Mix sorbet or sherbet ingredients in the frozen *freezer canister* by turning the switch to “YOGURT” consistency for 40 minutes. Turn off the ice cream maker and put the *freezer canister* back into your freezer for about 1 hour before serving.

*NOTE:

- Always freeze the *freezer canister* in the inner top shelf of your freezer for 24 to 48 hours before starting to make ice cream.
- The stirred ice cream mixture in *freezer canister* will not harden until it is placed back into freezer for 2 to 4 hours.
- Your homemade ice cream is all natural and may not taste as creamy or have the same consistency as commercial brands of ice cream.
- Once HARD has been selected the mixture has started to freeze, **DO NOT SWITCH TO SOFT**. The faster speed (SOFT SELECTION) can not spin the hard ice cream.

HELPFUL TIPS

- ✓ Ice cream recipes that require pre-cooking, making the mixture a day ahead is recommended. The mixture will then be able to cool completely and expand. Pre-chilling any ice cream mixture is suggested for achieving the best results.
- ✓ The ingredient mixtures that do not require cooking are made best with an electric mixer or a blender, which lets the mixture to become smooth and increase in its volume.
- ✓ The richer the cream you use, the richer flavor the ice cream will be. The whipped heavy cream is suggested for creamier, smoother ice cream.
- ✓ Milk can also be substituted for cream, but the ice cream's texture and taste may change. You might consider using a combination of milk and cream.
- ✓ Please note that when using vanilla extract in making ice cream, always add it at the very last. Since the alcohol in vanilla extract will burn and hinder the speed of hardening the ice cream, you may add vanilla extract to the mixture when the ice cream maker has already spinned for 20 minutes.
- ✓ Artificial sweeteners may be substituted for sugar. Use the following portion as a reference:
 - 1 packet of sweetener = 2 tsp. sugar
 - 6 packets = 1/4 cup
 - 8 packets = 1/3 cup
 - 12 packets = 1/2 cup
- ✓ Add alcohol minutes before the process is completed, if a recipe calls for it.
- ✓ You may taste the mixture to adjust the amount of sugar to be added into it. Be aware that the actual ice cream will taste less sweet than the mixture.

HOW TO CLEAN

1. Wash the cover, mixing paddle, and freezer canister in warm soapy water using a sponge or dishcloth.
2. Rinse and dry all parts thoroughly.
3. Wipe motor base with a damp cloth.

CAUTIONS

- **DO NOT IMMERSE THE MOTOR BASE IN WATER OR OTHER LIQUID.**
- **DO NOT CLEAN WITH ABRASIVE CLEANERS OR HARD IMPLEMENTS.**
- **DO NOT FREEZE THE FREEZER CANISTER IF IT IS STILL WET.**

**ADDITIONAL FREEZER CANISTER WITH A LID IS AVAILABLE. IF YOU NEED IT, PLEASE CALL OUR CUSTOMER SERVICE DEPARTMENT FOR PURCHASE.
CALL: 1-800-276-6286**

ICE CREAM RECIPES

VANILLA ICE CREAM

1 1/2 cups half and half
1 cup sugar
1 tablespoon vanilla extract
2 cups cream

Combine all ingredients in freezer canister of the ice cream maker. Freeze as instructed. Makes about 1 quart.

More Choices

- ❖ You may always add crushed cookies, chopped cherries or swirl sauces such as chocolate fudge sauce into ice cream minute before freezing for more flavors.

OLD FASHIONED CHOCOLATE ICE CREAM

1 1/2 cups half and half
1/2 cup cocoa powder
1/2 cup sugar
2 teaspoons vanilla extract
2 cups cream

Combine half and half, cocoa powder, sugar, and vanilla in a blender container. Process the ingredients at low speed until smooth. Pour mixture into freezer canister. Stir in cream. Freeze as instructed. Makes about 1 quart.

MOCHA ICE CREAM

1 1/2 cups half and half
1/2 cup sugar
1/2 cup cocoa powder
2 teaspoons instant coffee powder
2 teaspoons vanilla extract
2 cups cream

Combine half and half, cocoa powder, coffee powder, sugar, and vanilla in a blender container. Process the ingredients until smooth. Pour mixture into freezer canister. Stir in cream. Freeze as instructed. Makes about 1 quart.

PEANUT BUTTER ICE CREAM

3 cups half and half
1/2 cup peanut butter
1/2 cup sugar
2 teaspoons vanilla extract

Combine half and half, peanut butter, and sugar in a saucepan. Cook over low heat until sugar is dissolved. Mix in vanilla extract. Chill the mixture in the refrigerator. Pour the mixture into Freezer Canister. Freeze as instructed.
Makes about 1 quart.

PEACH ICE CREAM

2 cups half and half
1/4 cup sugar
2 1/2 cups finely chopped peaches
2 tablespoons lime juice
2 teaspoons vanilla extract

Combine all ingredients except peaches in a blender and process until smooth. Add peaches. Chill in the refrigerator until ready to freeze. Pour the mixture into the canister of the ice cream maker. Freeze as instructed.
Makes about 1 quart.

More Choices:

Peaches may be substituted with other soft texture fresh fruits such as strawberries or blueberries..., etc.

BLACK WALNUT ICE CREAM

3 1/2 cups half and half
2 teaspoons vanilla extract
1/4 teaspoon black walnut extract.
Dash salt
1/2 cup finely chopped black walnuts

Combine all ingredients except chopped walnuts in a blender. Process until smooth. Chill in refrigerator. Pour mixture into freezer canister. Freeze as instructed. Add chopped walnuts right before ice cream is frozen. Continue freezing until ice cream is done.

Makes about 1 quart.

More Choices:

Almond extract and chopped almonds may be used to make almond ice cream.

MINT CHOCOLATE CHIP ICE CREAM

1 1/2 cups half and half
3/4 cup sugar
1 1/2 teaspoons vanilla extract
1 drop green food coloring
1/2 cup chopped chocolate chips
2 cups cream
1 teaspoon mint extract

Combine all ingredients except chocolate chips in freezer canister. Stir until sugar is dissolved. Freeze as instructed. Add chocolate chips minute before freezing.

Makes about 1 quart.

COFFEE ICE CREAM

1 1/2 cups half and half
3/4 cup sugar
1 1/2 tablespoons instant coffee powder
1 teaspoon vanilla extract
2 cups cream

Combine all ingredients in freeze canister. Stir well until both sugar and instant coffee powder are dissolved. Freeze as instructed.

Makes about 1 quart.

NOTE:

The recipes are ordered to make about 1 quart of ice cream. You may increase 2 cups of half and half or 1 cup half and half and 1 cup cream to make about 1 1/2 quarts of ice cream. Please remember to increase the amount of other ingredients accordingly.

FROZEN YOGURT & CUSTARD

RASEBERRY FROZEN YOGURT

1 cup raspberries fresh or frozen
1 cup sugar
3 cups plain yogurt

Place raspberries and sugar in a blender. Process until smooth. Pour into freeze canister. Stir in yogurt. Freeze as instructed. Makes about 1 quart.

More Choices:

Raspberries can be substituted with peaches, blueberries or strawberries.

VANILLA FROZEN YOGURT

1 cup half and half
2/3 cup sugar
2 teaspoons vanilla extract
2 cups plain yogurt

Combine all ingredients in a blender. Process until smooth. Pour the mixture into freezer canister. Freeze as instructed.

MOCHA CUSTARD

1 cup half and half
3/4 cup sugar
1/2 cup cocoa powder
2 teaspoons instant coffee powder
4 egg yolks
2 teaspoons vanilla extract
2 cups cream

Combine all ingredients except cream and vanilla extract in a blender. Process at a low speed until smooth. Pour mixture into a saucepan. Cook over low heat. Chill in refrigerator. Pour into freezer canister. Stir in cream and vanilla extract. Freeze as instructed.

Makes about 1 quart.

VANILLA CUSTARD

1 1/2 cup half and half

3/4 cup sugar

4 egg yolks

1 tablespoon vanilla extract

2 cups cream

Combine half and half, sugar and egg yolks in a saucepan. Cook over low heat. Chill in refrigerator. Pour into freezer canister. Stir in cream and vanilla extract. Freeze as instructed.

Makes about 1 quart.

SHERBET, SORBET & ICE

STRAWBERRY SHERBET

12 oz. finely chopped strawberries

2/3 cup sugar

3 1/2 cups milk

2 tablespoons orange juice

Pour all ingredients in a blender. Process until smooth. Pour mixture into the freezer canister. Freeze as instructed.

Makes about 1 quart.

More Choices:

Fresh fruits such as raspberries, pineapple or watermelon may be used or mixed to create a variety of flavors of fruit sherbet.

BLACKBERRY SORBET

3 cups plain water
1/3 cup corn syrup
1 quart blackberries
2 tablespoons lemon juice

Place all ingredients into a blender. Process at MEDIUM speed until smooth. Pour mixture into freezer canister using a strainer. Freezer as instructed.
Makes about 1 quart.

PINEAPPLE SORBET

3 cups plain water
1/3 cup corn syrup
1 quart sliced canned pineapple
2 tablespoons lemon juice

Place all ingredients into a blender. Process at MEDIUM speed until smooth. Pour mixture into freezer canister using a strainer. Freezer as instructed.
Makes about 1 quart.

ESPRESSO ICE

1/2 cup half and half
3 tablespoons instant coffee powder
3 cups hot water
3/4 cup sugar

Dissolve coffee powder and sugar in hot water. Add half and half. Chill in refrigerator until ready to use. Pour into freezer canister. Freeze as instructed.
Makes about 1 quart.

LIMITED WARRANTY

Aroma Housewares Company warrants this product free from defects in material and workmanship for one year from provable date of purchase in the United States.

Within this warranty period, Aroma Housewares Company will repair or replace, at its option, defective parts at no charge, provided the product is returned, freight prepaid with proof of purchase and U.S. \$6.00 for shipping and handling charges to Aroma Housewares Company. Please call the toll free number below for return authorization number. Allow 2-4 weeks for return shipping.

This warranty does not cover improper installation, misuse, abuse or neglect on part of the owner. Warranty is also invalid in any case that the product is taken apart or serviced by an unauthorized service station.

This warranty gives you specific legal rights and they may vary from state to state and does not cover areas outside the United States.

AROMA HOUSEWARES COMPANY
6469 Flanders Drive
San Diego, California 92121
1-800-276-6286
M-F, 8:30 AM - 5:00 PM, Pacific Time
Website: www.aromaco.com

