

AROMA[®]
PROFESSIONAL



instruction manual

ARC-1240W

Rice & Grain Multicooker

Questions or concerns about your Aroma product?
www.AromaCo.com/Support
1-800-276-6286

DISCOVER
more of our
products!



Digital Rice & Grain
Multicookers



Rice & Grain
Cookers



Electric Kettles



Indoor Grills



...and More!

AROMA®

To Enhance and Enrich Lives.

Here at Aroma we strive to make a difference—to design and distribute products that enhance and enrich people's lives.

Aroma offers an array of exceptional products to make cooking simple and satisfying. Discover other countertop appliances and cookware from our current product lineup to complement your kitchen.

REGISTER YOUR PRODUCT



Registration is quick and easy.

Be notified of:

- new product releases
- new test kitchen recipes
- sales and promotions
- ...and more!

SCAN TO REGISTER
[AromaCo.com/registration](https://www.AromaCo.com/registration)



/AromaHousewares



IMPORTANT SAFEGUARDS

Basic safety precautions should always be followed when using electrical appliances, including the following:

1. **Important: Read all instructions carefully before first use.**
2. Do not touch hot surfaces. Use the handles or knobs.
3. Use only on a level, dry and heat-resistant surface.
4. To protect against fire, electric shock and injury to persons, do not immerse cord, plug or the appliance in water or any other liquid. See instructions for cleaning.
5. Close supervision is necessary when the appliance is used by or near children.
6. Unplug from outlet when not in use and before cleaning. Allow unit to cool before putting on or taking off parts and before cleaning the appliance.
7. Do not operate any appliance with a damaged cord or plug or after the appliance malfunctions or has been damaged in any manner. Contact Aroma® customer service for examination, repair or adjustment.
8. The use of accessory attachments not recommended by Aroma® Housewares may result in fire, electrical shock or injury.
9. Do not use outdoors.
10. Do not let cord touch hot surfaces or hang over the edge of a counter or table.
11. Do not place on or near a hot gas or electric burner or in a heated oven.
12. Do not use the appliance for anything other than its intended use.
13. Extreme caution must be used when moving the appliance containing rice, hot oil or other liquids.
14. Do not touch, cover or obstruct the steam vent on the top of the cooker as it is extremely hot and may cause scalding.
15. Use only with a 120V AC power outlet.
16. Always unplug from the plug gripping area. Never pull on the cord.
17. The cooker should be operated on a separate electrical circuit from other operating appliances. If the electrical circuit is overloaded with other appliances, the appliance may not operate properly.
18. Always make sure the outside of the inner pot is dry prior to use. If the inner pot is returned to the cooker when wet, it may damage or cause the product to malfunction.
19. Use extreme caution when opening the lid during or after cooking. Hot steam will escape and may cause scalding.
20. Rice should not be left in the inner pot with the **Keep Warm** function on for more than 24 hours.
21. To disconnect, turn any control to OFF, then remove the plug from the wall outlet. Always attach plug to appliance first, then plug into the wall outlet.
22. To reduce the risk of electrical shock, cook only in the removable inner pot provided.
23. Do not wrap or tie cord around appliance.
24. Intended for countertop use only.
25. **WARNING:** Spilled food can cause serious burns. Keep appliance and cord away from children. Never drape cord over edge of counter, never use outlet below counter, and never use with an extension cord.
26. Do not use for deep frying.
27. To prevent damage or deformation, do not use the inner pot on a stovetop or burner.



IMPORTANT SAFEGUARDS

Short Cord Instructions

A short power-supply cord is provided to reduce the risks resulting from it being grabbed by children, and becoming entangled in or tripping over a longer cord.

DO NOT DRAPE CORD!

KEEP AWAY FROM CHILDREN!

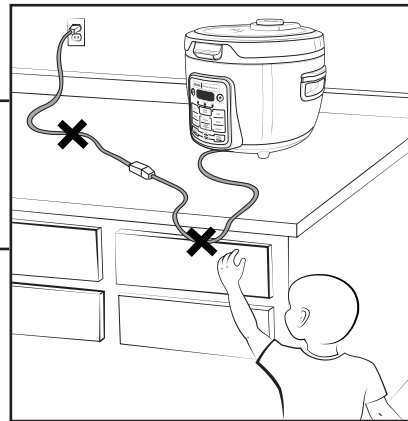

Polarized Plug

This appliance has a polarized plug (one blade is wider than the other); follow the instructions below:

To reduce the risk of electric shock, this plug is intended to fit into a polarized outlet only one way. If the plug does not fit fully into the outlet, reverse the plug. If it still does not fit, contact a qualified electrician. Do not attempt to modify the plug in any way.

If the supply cord is damaged, it must be replaced by the manufacturer, its service agent or a similarly qualified person in order to avoid a hazard.

THIS APPLIANCE IS FOR HOUSEHOLD USE ONLY.

Parts Identification

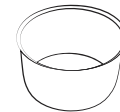
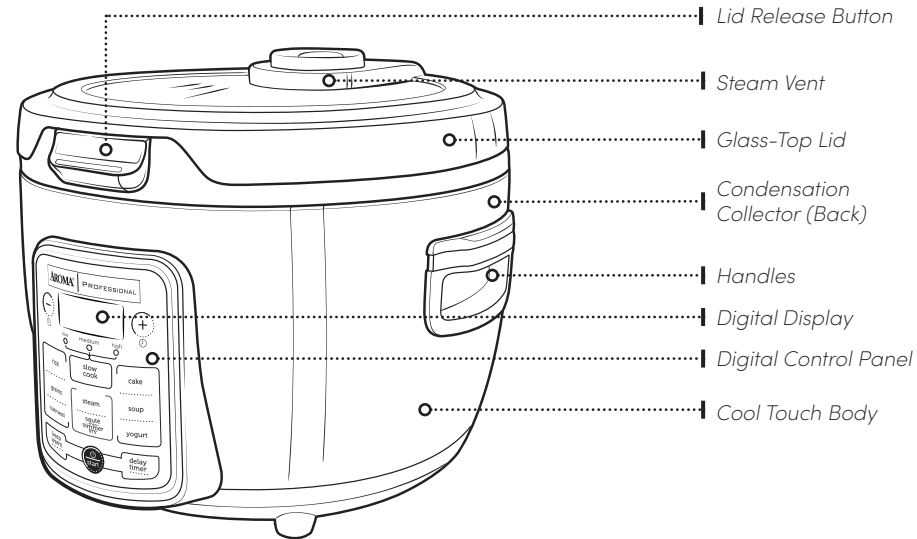

Nonstick Inner Pot

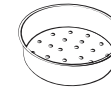

Steam Tray



Rice Measuring Cup



Serving Spatula

Digital Controls

Rice

Cooks fluffy, delicious white rice automatically.

Grains

Makes a variety of grains including quinoa, barley, couscous, brown rice and bulgur with ease.

Oatmeal

Prepares a quick and healthy breakfast with no need to stir or monitor.

Slow Cook

Prepare homemade roasts, stews and other slow-cooked favorites with an adjustable cook time of 2 to 10 hours.

Steam

Using the included steam tray, steaming healthy sides and main courses has never been easier.

Cake

Easily bakes cakes and other sweet batter-based treats.

Soup

Simmers your favorite hot and hearty soups with an adjustable cook time of 2 to 8 hours.

Sauté-Then-Simmer STS®

Sautés foods on high heat then automatically switches to simmer mode once liquid is added. Great for risotto, Spanish rice, chili, stir-fries and much more!

Yogurt

Low-heat cooking cycle prepares tasty yogurt in 6-12 hours.

Keep Warm

Manually sets the cooker to **Keep Warm** mode, perfect for keeping foods at ready-to-serve temperatures.

Delay Timer

Allows for food to be ready right when it's needed with preparation up to 15 hours in advance.

(⏻)/Start

Powers the cooker on and off or cancels a current function.

BEFORE FIRST USE

1. Read all instructions and important safeguards.
2. Remove all packaging materials and check that all items have been received in good condition.
3. Tear up all plastic bags and dispose of them properly as they can pose a risk to children.
4. Remove the nonstick inner pot from the cooker and clean with warm, soapy water.
5. Wash all accessories in warm, soapy water.
6. Wipe the cooker's body clean with a damp cloth.
7. Dry all parts thoroughly then assemble for use.
.....

TO CLEAN

1. Remove the inner pot when the cooker has completely cooled.
2. Hand wash the inner pot and all accessories using warm, soapy water or place on the top rack of the dishwasher.
3. Remove the condensation collector and hand wash using warm, soapy water.
4. Wipe the cooker's body clean with a damp cloth.
5. Thoroughly dry the cooker's body and all accessories. Reassemble for next use.
.....

TROUBLESHOOTING

Rice is too dry/hard after cooking.

- Depending on how dry your rice is, add ½ to 1 cup of water and stir thoroughly. Close the lid and select the **Rice** function once more. When the cooker switches to **Keep Warm**, open the lid and stir the rice to check the consistency. Repeat as necessary until rice is soft and moist.

Rice is too moist/soggy after cooking.

- Use the serving spatula to stir the rice to redistribute the bottom (moist) part of the rice as well as release excess moisture. Close the lid and allow the cooker to remain on **Keep Warm** for 10-30 minutes as needed, opening the lid and stirring periodically to release excess moisture.

6.



Caution:

Do not use harsh abrasive cleaners, scouring pads or products that are not considered safe to use on nonstick coatings.

We recommend hand washing the inner pot with warm, soapy water to lengthen its lifespan and avoid damage over time. If washing in a dishwasher, a slight discoloration to the inner pot may occur. This is cosmetic and will not negatively affect performance.

Before placing the inner pot into the cooker, check that the inner pot is dry and free of debris. Adding the inner pot when wet may damage the cooker.

Note:

- To remove the condensation collector, squeeze both sides and pull out towards you.
- Any other servicing should be performed by Aroma® Housewares.
- Not satisfied with your Aroma® purchase? Our product experts can help! **Before returning, please contact Customer Service at 1-800-276-6286** for product support, helpful tips and more!

Error Code Chart

If an error shows on the digital display, the following chart will help explain the next course of action.

DISPLAY CODE	ACTION
E1 or E3	Turn off the rice cooker. Allow to cool for 2-5 minutes then restart. If the problem persists, contact Customer Service: 1-800-276-6286
E2 or E4	Contact Customer Service: 1-800-276-6286

RICE & GRAIN

1. Using the provided rice measuring cup, add rice or grain to the inner pot.
2. Rinse to remove excess starch. Drain.
3. For white or brown rice, fill with water to the line that matches the number of cups of rice being cooked. For other grains, see "Rice/Grain & Water Measurement Tables" on page 15.
4. Place the inner pot into the cooker and close the lid securely.
5. Plug the power cord into an available 120V AC wall outlet.
6. Press (⏻)/**Start** to turn the cooker on.
7. Press **Rice** or **Grains** depending on the type of grain being cooked, then press (⏻)/**Start**.
8. The cooking indicator light will illuminate and the digital display will show a chasing pattern as the cooker begins heating.
9. The digital display will count down the final 10 minutes of cook time.
10. Once the cycle has completed, the cooker will beep and automatically switch to **Keep Warm**.
11. For best results, stir the grain with the serving spatula to distribute any remaining moisture.
12. When finished, turn the cooker off by pressing (⏻)/**Start** twice and unplug the power cord.
.....



Caution:

The rice cooker will not switch to **Warm** mode until all liquid has evaporated. Follow your recipe carefully and do not leave the rice cooker unattended.

Note:

- Because rice varieties may vary in their make-up, results may differ.
- Food should not be left in the cooker on **Keep Warm** for more than 24 hours.
- Rinse rice before placing it into the inner pot to remove excess bran and starch. This will help reduce browning and sticking to the bottom of the pot.

Helpful Hints:

- If you misplace the measuring cup, a ¾ standard U.S. cup is an exact replacement.
- To add more flavor to rice, try substituting water for a favorite meat or vegetable broth or stock. The ratio of broth/stock to rice will be the same as water to rice.
- For approximate rice cooking times and suggested rice/water ratios, see "Rice/Grain & Water Measurement Tables" on page 15.

7.

OATMEAL

1. Using the provided rice measuring cup, add oatmeal to the inner pot.
2. Fill the inner pot with water according to packaging instructions. When an oatmeal to water ratio is not available, use a ratio of 1:3.
3. Place the inner pot into the cooker and close the lid securely.
4. Plug the power cord into an available 120V AC outlet.
5. Press (⏻)/**Start** to turn the cooker on.
6. Press **Oatmeal**, then press (⏻)/**Start**. The cooking indicator light will illuminate and the digital display will show a chasing pattern as the cooker begins heating.
7. Once the cycle has completed, the cooker will beep and automatically switch to **Keep Warm**.
8. When finished, turn the cooker off by pressing (⏻)/**Start** twice and unplug the power cord.
.....

DELAY TIMER

1. Using the provided rice measuring cup, add rice or grain to the inner pot.
2. Rinse to remove excess starch. Drain.
3. For white or brown rice, fill with water to the line that matches the number of cups of rice being cooked. For other grains, see "Rice/Grain & Water Measurement Tables" on page 15.
4. Place the inner pot into the cooker and close the lid securely.
5. Plug the power cord into an available 120V AC wall outlet.
6. Press (⏻)/**Start** to turn the cooker on.
7. Press **Delay Timer**.
8. Press (+) or (-) to increase or decrease the delay time by one hour increments. It may be set to have grains ready in 1 to 15 hours for **Rice** or **Oatmeal** and 2 to 15 hours for **Grains**.
9. Once the desired time is selected, press the **Rice**, **Grains**, or **Oatmeal** button, depending on the type of grain being cooked. The cooker will beep and the digital display will stop flashing to indicate that the time has been successfully set.

8.



Caution:

The cooker will not switch to **Keep Warm** mode until all liquid has evaporated. Follow your recipe carefully and do not leave the cooker unattended.

Do not attempt to cook more than 2 cups of oatmeal in this appliance at one time.

Note:

Food should not be left in the cooker on **Keep Warm** for more than 24 hours.

Helpful Hints:

For approximate grain cooking times and suggested grain/water ratios, see "Rice/Grain & Water Measurement Tables" on page 15.

The provided rice measuring cup is equivalent to a ¾ standard U.S. cup.



DELAY TIMER (CONT.)

10. Press (⏻)/**Start** to begin the cooking cycle.
11. The digital display will count down from the input delay time.
12. Once the delay time has elapsed, a chasing pattern will appear in the digital display signifying that the cooking cycle has begun.
13. The digital display will count down the final 10 minutes of cook time.
14. Once the cycle has completed, the cooker will beep and automatically switch to **Keep Warm**.
15. When finished, turn the cooker off by pressing (⏻)/**Start** twice and unplug the power cord.
.....

SOUP

1. Add desired ingredients to the inner pot.
2. Place the inner pot into the cooker and close the lid securely.
3. Plug the power cord into an available 120V AC wall outlet.
4. Press (⏻)/**Start** to turn the cooker on.
5. Press **Soup**. The digital display will show a flashing "2" to represent 2 hours of cook time.
6. Press (+) or (-) to increase or decrease time by 1 hour increments, up to 8 hours.
7. Once the time has been selected, press (⏻)/**Start**.
8. The cooker will beep and the digital display will stop flashing to indicate that the time has been successfully set.
9. The cooker will now begin heating. The digital display will count down in one minute increments from the input cook time after it reaches a boil.
10. Using caution, open the lid after contents reach a boil and stir the ingredients with a long-handled wooden or heat-safe utensil if desired.
11. Once the time has elapsed, the cooker will beep and automatically switch to **Keep Warm**.
12. When finished, turn the cooker off by pressing (⏻)/**Start** twice and unplug the power cord.
.....



Caution:

Do not use the provided serving spatula to stir ingredients while using the **Sauté-Then-Simmer**®, **Slow Cook**, or **Soup** functions. It is not intended to be used in contact with high temperatures. Instead, use a long-handled wooden or heat-safe utensil to stir while cooking.

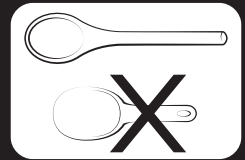

9.

STEAM

- Using the provided rice measuring cup, add 3 cups of water to the inner pot.
- Place the inner pot into the cooker.
- Place desired food into the provided steam tray, lower the tray into the cooker then close the lid securely.
- Plug the power cord into an available 120V AC outlet.
- Press (⏻)/**Start** to turn the cooker on.
- Press **Steam**. The digital display will show a flashing "5" to represent five minutes of steam time.
- Press (+) or (-) to increase or decrease steaming time by one minute increments, up to 30 minutes. For suggested steaming times for meat and vegetables, see "Meat & Vegetable Steaming Tables" on page 11.
- Once the desired time is selected, press (⏻)/**Start** to begin the cooking cycle.
- Once the water reaches a boil, the digital display will begin to count down from the input steam time.
- After the selected steam time has elapsed, the cooker will beep and automatically switch to **Keep Warm**.
- Using caution, check to see that the steamed food is cooked. If finished steaming, carefully remove the food to prevent overcooking. Wear a protective heat-resistant glove to prevent injury as the steam tray will be hot.
- When finished, turn the cooker off by pressing (⏻)/**Start** twice and unplug the power cord.

STEAM & COOK

- To steam foods while cooking grains, begin cooking grain by following steps 1 through 7 of "Rice & Grain" on page 7.
- Place the desired food into the provided steam tray. Open the lid using caution, lower the steam tray into the cooker then close the lid securely.
- Cook food according to "Meat & Vegetable Steaming Tables" on page 11.



Caution:

Do not attempt to cook more than 6 cups of uncooked rice when steaming and cooking simultaneously.

Before placing the inner pot into the cooker, check that it is dry and free of debris. Adding the inner pot when wet may damage the cooker.

Helpful Hints:

Parchment paper or aluminum foil may also be used while steaming. Place the paper/foil in the center of the steam tray and ensure it does not create a seal along the bottom of the tray.

We recommend beginning to steam your foods towards the end of the rice cooking cycle. This will allow steamed food and cooked grains to be ready around the same time. See "Rice/Grain & Water Measurement Tables" on page 15 for approximate cooking times.

STEAM & COOK (CONT.)

- After the suggested amount of time has elapsed, open the lid to check steamed food for doneness. Use caution when opening the lid as hot steam will escape.
- If food is finished steaming, remove the steam tray. Wear a protective heat-resistant glove to prevent injury as the steam tray will be hot.
- Close the lid securely and allow the cooking cycle to continue.
- Once the cycle has completed, the cooker will beep and automatically switch to **Keep Warm**.
- When finished, turn the cooker off by pressing (⏻)/**Start** twice and unplug the power cord.

Meat & Vegetable Steaming Tables

Meat	Steaming Time	Safe Internal Temperature
Fish	25 Min.	140°F
Chicken	30 Min.	165°F
Pork	30 Min.	160°F
Beef	Medium = 25 Min. Medium-Well = 30 Min. Well = 33 Min.	160°F

Vegetable	Steaming Time
Asparagus	8-12 Minutes
Broccoli	10-15 Minutes
Cabbage	7-11 Minutes
Carrots	8-12 Minutes
Cauliflower	10-15 Minutes
Corn on the Cob	20-25 Minutes
Green Beans	9-13 Minutes
Peas	6-10 Minutes
Spinach	5 Minutes
Squash	8-12 Minutes
Zucchini	8-12 Minutes
Potatoes	25-30 Minutes

Helpful Hints:

Since most vegetables only absorb a small amount of water, there is no need to increase the amount of water with a larger serving of vegetables.

To ensure meat tastes its best and to prevent food-borne illness, check that the meat is completely cooked prior to serving. If the meat is still uncooked, simply add more water to the inner pot and repeat the steaming process until the meat is adequately cooked.

Note:

- Altitude, humidity and outside temperature will affect cooking times.
- These steaming charts are for reference only. Actual cooking times may vary.
- Food should not be left in the rice cooker on **Keep Warm** for more than 24 hours.
- When steaming, Aroma® recommends using 3 cups of water with the provided rice measuring cup.

SAUTÉ-THEN-SIMMER®

1. Place the inner pot into the cooker.
2. Plug the power cord into an available 120V AC wall outlet.
3. Press (⏻)/**Start** to turn the cooker on.
4. Press **Sauté-then-Simmer**®, then press (⏻)/**Start**. The cooking indicator light will illuminate as the cooker begins to heat.
5. Add oil if desired for sautéing then close the lid securely and allow the inner pot to preheat for 2–4 minutes.
6. Once preheated, add in ingredients to sauté.
7. When finished sautéing, stir in any other desired ingredients including liquid and close the lid securely.
8. The cooker will automatically reduce its heat and switch to simmer mode once liquids are added.
9. Once all liquid has been evaporated, the cooker will beep and automatically switch to **Keep Warm**.
10. When finished, turn the cooker off by pressing (⏻)/**Start** twice and unplug the power cord.
.....

SLOW COOK

1. Add desired ingredients to the inner pot.
2. Place the inner pot into the cooker and close the lid securely.
3. Plug the power cord into an available 120V AC wall outlet.
4. Press (⏻)/**Start** to turn the cooker on.
5. Press **Slow Cook** once for High, twice for Medium and three times for Low.
6. Press (-) or (+) to adjust cook time in 30-minute increments. Low time setting can be set 7–10 hours, Medium set 4–6 hours and High 1–3 hours.
7. Once the needed cooking time is selected, the cooker will beep to indicate it is setting at the displayed time. The display will stop flashing to indicate it has set.
8. The cooker will begin to slow cook. The digital display will count down in one minute increments from the selected time.



Caution:

Do not use the provided serving spatula to stir ingredients while using the **Sauté-Then-Simmer**®, **Slow Cook**, or **Soup** functions. It is not intended to be used in contact with high temperatures. Instead, use a long-handled wooden or heat-safe utensil to stir while cooking.

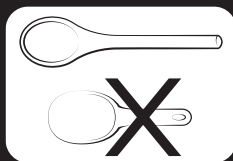

Note:

Slow cooking requires a small amount of liquid. Without liquid, the cooker will automatically switch to **Keep Warm**.

SLOW COOK (CONT.)

9. Using caution, open the lid occasionally and stir the ingredients with a long-handled wooden or heat-safe spoon if desired.
10. Once the time has elapsed, the cooker will beep and automatically switch to **Keep Warm**.
11. When finished, turn the cooker off by pressing (⏻)/**Start** twice and unplug the power cord.
.....

CAKE

1. Prepare one prepackaged cake mix according to the instructions or prepare your own cake batter.
2. Spray the interior of the inner pot with nonstick cooking spray.
3. Pour the cake mixture into the inner pot.
4. Place the inner pot into the cooker then close the lid securely.
5. Plug the power cord into an available 120V AC wall outlet.
6. Press (⏻)/**Start** to turn the cooker on.
7. Press **Cake**, then press (⏻)/**Start**. The cooking indicator light will illuminate as the cooker begins heating.
8. Once the cycle has completed, the cooker will beep and automatically switch to **Keep Warm**.
9. When finished, turn the cooker off by pressing (⏻)/**Start** twice and unplug the power cord.
.....

YOGURT

1. Add 8 cups of whole milk to the inner pot.
2. Place the inner pot into the cooker and close the lid securely.
3. Plug the power cord into an available 120V AC wall outlet.
4. Press (⏻)/**Start** to turn the cooker on.
5. Press **Sauté-then-Simmer STS**® and then (⏻)/**Start** to begin heating the milk to 180°F. The cooking indicator light will illuminate as the cooker begins to heat.

continued on the next page >>



Caution:

The cooker will not switch to **Keep Warm** mode until all liquid has evaporated. Follow your recipe carefully and do not leave the cooker unattended.

Do not attempt to cook more than one package of cake mix (15.25 oz.) in this appliance at one time.

Note:

Food should not be left in the cooker on **Keep Warm** mode for more than 24 hours.

YOGURT (CONT.)

6. Using caution, open the lid and stir the milk every 5 minutes with a long-handled wooden or heat-safe utensil.
7. Monitor the temperature using a kitchen thermometer. Once the milk reaches 180°F (after about 25 minutes), press (⏻)/**Start** to cancel the cooking process.
8. Using oven mitts, carefully remove the inner pot from the cooker and place on a heat-safe surface to cool. Allow the milk to cool to 115°F (approximately 30–45 minutes).
9. Once cooled, combine 1 cup of the milk with ½ cup yogurt or starter culture in a glass bowl and mix well. Add the mixture back into the inner pot and stir to combine.
10. Carefully place the inner pot back into the cooker, making sure that the exterior is clean and dry.
11. Press (⏻)/**Start** to turn the cooker on.
12. Press **Yogurt**. The digital display will show a flashing "8:00" to represent 8 hours of cook time. Press (+) or (-) to increase or decrease cook time by one hour increments, from 6–12 hours.
13. Once the time has been selected, press (⏻)/**Start**. The cooker will beep and the digital display will stop flashing to indicate that the time has been successfully set.
14. The cooker will now begin heating. The digital display will count down in one minute increments from the input cook time.
15. Once the time has elapsed, the cooker will beep and automatically switch to standby mode.
16. Pour off any liquid from the top or strain the yogurt using cheesecloth for a thicker consistency.
17. When finished, turn the cooker off by pressing (⏻)/**Start** and unplug the power cord.
18. Store and refrigerate yogurt in an airtight container or transfer yogurt into small glass jars with lids as individual servings.

Note:

- Opening the lid during the cooking cycle causes a loss of heat and steam. Cooking time may be prolonged if the lid is opened before the food is finished.
- Cooking times are approximate. Altitude, humidity and outside temperature will affect cooking times.

Rice & Water Measurement Table

Uncooked Rice*	Water: Using the Water Line (inside nonstick pot)	Water: Using the Rice Measuring Cup*	Approx. Cooked Rice Yield*	Cooking Times
2 Cups	White Rice: Line 2 Brown Rice: Line 2	White Rice: 2¾ Cups Brown Rice: 2¾ Cups	4 Cups	White Rice: 30–36 Min. Brown Rice: 49–55 Min.
3 Cups	White Rice: Line 3 Brown Rice: Line 3	White Rice: 4 Cups Brown Rice: 4 Cups	6 Cups	White Rice: 33–39 Min. Brown Rice: 52–58 Min.
4 Cups	White Rice: Line 4 Brown Rice: Line 4	White Rice: 5¼ Cups Brown Rice: 5¼ Cups	8 Cups	White Rice: 35–41 Min. Brown Rice: 55–61 Min.
5 Cups	White Rice: Line 5 Brown Rice: Line 5	White Rice: 6½ Cups Brown Rice: 6½ Cups	10 Cups	White Rice: 38–44 Min. Brown Rice: 58–64 Min.
6 Cups	White Rice: Line 6 Brown Rice: Line 6	White Rice: 7¾ Cups Brown Rice: 7¾ Cups	12 Cups	White Rice: 40–46 Min. Brown Rice: 60–66 Min.
7 Cups	White Rice: Line 7 Brown Rice: Line 7	White Rice: 9 Cups Brown Rice: 9 Cups	14 Cups	White Rice: 43–49 Min. Brown Rice: 63–69 Min.
8 Cups	White Rice: Line 8 Brown Rice: Line 8	White Rice: 10 Cups Brown Rice: 10 Cups	16 Cups	White Rice: 45–51 Min. Brown Rice: 65–71 Min.
9 Cups	White Rice: Line 9 Brown Rice: Line 9	White Rice: 11 Cups Brown Rice: 11 Cups	18 Cups	White Rice: 48–54 Min. Brown Rice: 68–74 Min.
10 Cups	White Rice: Line 10 Brown Rice: Line 10	White Rice: 12 Cups Brown Rice: 12 Cups	20 Cups	White Rice: 50–56 Min. Brown Rice: 70–76 Min.

Grain & Water Measurement Table

Grain	Uncooked Grain	Liquid	Approx. Cooked Grain Yield	Max. Uncooked Grain*	Function	Cooking Times
Quinoa	1 Part	1½ Parts	2 Cups	7 Cups	Rice	32–48 Min.
Arborio	1 Part	2 Parts	2 Cups	5 Cups	Steam	12–17 Min.
Barley	1 Part	2 Parts	1 Cup	2 Cups	Delay Timer & Grains	5 Hours
Bulgur	1 Part	2 Parts	2 Cups	7 Cups	Grains	35–50 Min.
Couscous	1 Part	1 Part	2 Cups	5 Cups	Rice	22–44 Min.

Note:

- **Do not place more than 10 cups of uncooked rice into the inner pot at one time.** The maximum capacity of this unit is 10 cups of uncooked rice which yields 20 cups of cooked rice.
- When cooking barley, you must use the **Delay Timer** for 4 hours in combination with the **Grains** function. The additional soaking time will ensure optimal flavor and texture. For best results when cooking barley or bulgur, let both grains sit on **Keep Warm** for 10 minutes before serving.
- If softer grains are desired, add an additional ½ cup of water or liquid.

RECIPES

Jalapeño Quinoa with Shallots

1 tbsp.	extra virgin olive oil
1	small shallot, minced
1	garlic clove, minced
2	jalapeño peppers, minced
2 cups	quinoa, thoroughly rinsed
2½ cups	chicken broth

Add olive oil to the inner pot and select the **Rice** function. Once heated, add the shallot, garlic, and jalapeños. Close the lid and allow the ingredients to cook, stirring occasionally with a long-handled wooden spoon. Once the shallot has softened, stir in the quinoa and chicken broth. Close the lid and cook until the quinoa is done, about 25 to 30 minutes. Serve while warm.

SERVES 4.
.....

One-Pot Pasta

2 cups	bow tie or penne pasta
2½ cups	chicken broth
1 cup	marinara sauce
1 cup	parmesan cheese
1 tsp.	olive oil
----	basil leaves, for garnish

Combine all ingredients except the cheese into the inner pot, ensuring they are evenly mixed. Close the lid and press **Rice**. Allow to cook, opening the lid and stirring occasionally. When the cooker switches to **Keep Warm**, open the lid and stir in the cheese until melted. Serve hot and garnish with basil leaves.

SERVES 4.
.....

RECIPES

Pulled Pork

1 lb.	boneless pork loin
¼	yellow onion, sliced
2½ tbsp.	chili powder
4 oz.	BBQ sauce
¼ cup	water

Press **Sauté-then-Simmer**® and allow the inner pot to heat for 5 minutes. Place the pork loin into the hot inner pot and brown for 4-5 minutes per side. Add remaining ingredients to the inner pot and stir. Press **Slow Cook (High)** and set for 2 hours, or until the meat easily shreds. Serve on warm slider buns.

SERVES 4.
.....

San Antonio Rice

2 cups	white rice
24 oz.	fresh salsa, mild or hot
2 tbsp.	vegetable oil
2 cups	corn kernels, fresh or canned
1 tsp.	ground cumin
1 tsp.	salt
2½ cups	water
----	fresh ground pepper, to taste
----	fresh minced cilantro, for garnish

Add all ingredients except the cilantro to the inner pot and stir. Close the lid and press **Rice**. Once the rice cooker switches to **Keep Warm**, carefully open the lid and stir. Allow to stand for 8-10 minutes before serving. Garnish with fresh cilantro and serve alone, or paired with grilled chicken or fish.

SERVES 4.
.....



To Enhance and Enrich Lives.



www.AromaCo.com